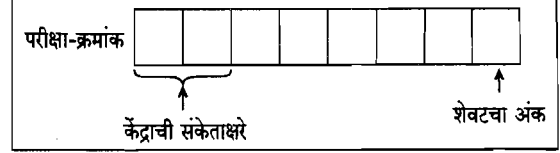

सूचना

- (1) सदर प्रश्नपुस्तिकेत 150 अनिवार्य प्रश्न आहेत. उमेदवारांनी प्रश्नांची उत्तरे लिहिण्यास सुरुवात करण्यापूर्वी या प्रश्नपुस्तिकेत सर्व प्रश्न आहेत किंवा नाहीत याची खात्री करून घ्यावी. असा तसेच अन्य काही दोष आढळल्यास ही प्रश्नपुस्तिका समवेक्षकांकडून लगेच बदलून घ्यावी.
- (2) आपला परीक्षा-क्रमांक ह्या चौकोनांत न विसरता बॉलपेनने लिहावा.

- (3) वर छापलेला प्रश्नपुस्तिका क्रमांक तुमच्या उत्तरपत्रिकेवर विशिष्ट जागी उत्तरपत्रिकेवरील सूचनेप्रमाणे न विसरता नमूद करावा.
- (4) या प्रश्नपुस्तिकेतील प्रत्येक प्रश्नाला 4 पर्यायी उत्तरे सुचविली असून त्यांना 1, 2, 3 आणि 4 असे क्रमांक दिलेले आहेत. त्या चार उत्तरांपैकी सर्वात योग्य उत्तराचा क्रमांक उत्तरपत्रिकेवरील सूचनेप्रमाणे तुमच्या उत्तरपत्रिकेवर नमूद करावा. अशा प्रकारे उत्तरपत्रिकेवर उत्तरक्रमांक नमूद करताना तो संबंधित प्रश्नक्रमांकासमोर छायांकित करून दर्शविला जाईल याची काळजी घ्यावी. ह्याकरिता फक्त काळ्या शाईचे बॉलपेन वापरावे, पेन्सिल वा शाईचे पेन वापरू नये.
- (5) सर्व प्रश्नांना समान गुण आहेत. यास्तव सर्व प्रश्नांची उत्तरे द्यावीत. घाईमुळे चुका होणार नाहीत याची दक्षता घेऊनच शक्य तितक्या वेगाने प्रश्न सोडवावेत. क्रमाने प्रश्न सोडविणे श्रेयस्कर आहे पण एखादा प्रश्न कठीण वाटल्यास त्यावर वेळ न घालविता पुढील प्रश्नांकडे वळावे. अशा प्रकारे शेवटच्या प्रश्नापर्यंत पोहोचल्यानंतर वेळ शिल्लक राहिल्यास कठीण म्हणून वगळलेल्या प्रश्नांकडे परतणे सोईस्कर ठरेल.
- (6) उत्तरपत्रिकेत एकदा नमूद केलेले उत्तर खोडता येणार नाही. नमूद केलेले उत्तर खोडून नव्याने उत्तर दिल्यास ते तपासले जाणार नाही.
- (7) प्रस्तुत परीक्षेच्या उत्तरपत्रिकांचे मूल्यांकन करताना उमेदवारांच्या उत्तरपत्रिकेतील योग्य उत्तरांनाच गुण दिले जातील. तसेच "उमेदवाराने वस्तुनिष्ठ बहुपर्यायी स्वरूपाच्या प्रश्नांची दिलेल्या चार उत्तरांपैकी सर्वात योग्य उत्तरेच उत्तरपत्रिकेत नमूद करावीत. अन्यथा त्यांच्या उत्तरपत्रिकेत सोडविलेल्या प्रत्येक चार चुकीच्या उत्तरांसाठी एका प्रश्नाचे गुण वजा करण्यात येतील".

ताकीद

ह्या प्रश्नपत्रिकेसाठी आयोगाने विहित केलेली वेळ संपेपर्यंत ही प्रश्नपुस्तिका आयोगाची मालमत्ता असून ती परीक्षाकक्षात उमेदवाराला परीक्षेसाठी वापरण्यास देण्यात येत आहे. ही वेळ संपेपर्यंत सदर प्रश्नपुस्तिकेची प्रत/प्रती, किंवा सदर प्रश्नपुस्तिकेतील काही आशय कोणत्याही स्वरूपात प्रत्यक्ष वा अप्रत्यक्षपणे कोणत्याही व्यक्तीस पुरविणे, तसेच प्रसिद्ध करणे हा गुन्हा असून अशी कृती करणाऱ्या व्यक्तीवर शासनाने जारी केलेल्या "परीक्षांमध्ये होणाऱ्या गैरप्रकारांना प्रतिबंध करण्याबाबतचा अधिनियम-82" यातील तरतुदीनुसार तसेच प्रचलित कायद्याच्या तरतुदीनुसार कारवाई करण्यात येईल व दोषी व्यक्ती कमाल एक वर्षाच्या कारावासाच्या आणि/किंवा रुपये एक हजार रकमेच्या दंडाच्या शिक्षेस पात्र होईल.

तसेच ह्या प्रश्नपत्रिकेसाठी विहित केलेली वेळ संपण्याआधी ही प्रश्नपुस्तिका अनधिकृतपणे बाळगणे हा सुद्धा गुन्हा असून तसे करणारी व्यक्ती आयोगाच्या कर्मचारीवृंदापैकी, तसेच परीक्षेच्या पर्यवेक्षकीयवृंदापैकी असली तरीही अशा व्यक्तीविरुद्ध उक्त अधिनियमानुसार कारवाई करण्यात येईल व दोषी व्यक्ती शिक्षेस पात्र होईल.

पुढील सूचना प्रश्नपुस्तिकेच्या अंतिम पृष्ठावर पहा

पर्यवेक्षकांच्या सूचनेविना हे सील उघडू नये

SEAL

कच्च्या कामासाठी जागा / SPACE FOR ROUGH WORK

1. The portion of the internal energy of a system associated with the kinetic energies of the molecules is called
- (1) Latent energy (2) Sensible energy
(3) Potential energy (4) Flow energy
-
2. The heat absorbed or rejected during a polytropic process is
- (1) $\left(\frac{\gamma - n}{\gamma - 1}\right) \times \text{work done}$ (2) $\left(\frac{\gamma - n}{\gamma - 1}\right)^2 \times \text{work done}$
(3) $\left(\frac{\gamma - n}{\gamma - 1}\right)^{1/2} \times \text{work done}$ (4) $\left(\frac{\gamma - n}{\gamma - 1}\right)^3 \times \text{work done}$
-
3. The first law of thermodynamics is essentially an expression of
- (1) conservation of mass principle
(2) conservation of momentum principle
(3) conservation of energy principle
(4) conservation of air principle
-
4. In a reversible cycle, the entropy of the system
- (1) increases (2) decreases
(3) does not change (4) first increases and then decreases
-
5. The loci of saturated liquid line and saturated vapour line meet at
- (1) critical point (2) boiling point
(3) ice point (4) triple point
-
6. "The cyclic integral at $\delta\theta/T$ is always less than zero" is called 'Clausius Inequality' and is valid for
- (1) all cycles, reversible and irreversible
(2) only reversible cycles
(3) only irreversible cycles
(4) None of the above

7. Availability Function is expressed as

- (1) $a = (U + P_0 V - T_0 S)$ (2) $a = (U + P_0 dV + T_0 dS)$
 (3) $a = (dU + P_0 dV - T_0 dS)$ (4) $a = (U + P_0 V + T_0 S)$

8. Multistage compression with inter-cooling is especially attractive when a gas is to be compressed at

- (1) very low pressure (2) normal pressure
 (3) very high pressure (4) None of the above

9. If tapered bar is subjected to tensile load, where diameter of rod varies from $(D + a)$ to $(D - a)$, the percentage error involved in calculation of Young's modulus using mean diameter is

- (1) $\left(\frac{a}{D}\right)^2$ (2) $\left(\frac{10a}{D}\right)^2$
 (3) D^2 (4) a^2

10. A simply supported beam of length 'L' is subjected to uniformly varying load whose intensity varies from zero at one support to 'W' at the other. Maximum bending moment in the beam is

- (1) $\frac{WL^2}{9\sqrt{3}}$ (2) $\frac{WL}{3}$
 (3) $\frac{WL^2}{\sqrt{3}}$ (4) $\frac{WL^3}{6\sqrt{3}}$

11. Simply supported beam of length 'L' is subjected to central point load 'W'. What is the strain energy stored in the beam, when 'E' is modulus of elasticity and 'I' is moment of inertia of section ?

- (1) $\frac{W^2 L^4}{96 EI}$ (2) $\frac{WL^3}{99 EI}$
 (3) $\frac{W^2 L^3}{96 EI}$ (4) $\frac{WL}{96 EI}$

कच्च्या कामासाठी जागा / SPACE FOR ROUGH WORK

12. When body is subjected to two mutually perpendicular like stresses σ_x and σ_y , then centre of the Mohr's circle from vertical axis is at

(1) $\frac{\sigma_x + \sigma_y}{2}$	(2) $\frac{\sigma_x - \sigma_y}{2}$
(3) $\frac{\sigma_x - \sigma_y}{2} + \tau_{xy}$	(4) $\frac{\tau_{xy}}{2}$

13. A beam of circular section is subjected to shear force. Then maximum shear stress across the section of beam is _____ greater than mean stress.

(1) 24%	(2) 29%
(3) 30.33%	(4) 33.33%

14. A beam of uniform section and length 'L' simply supported at ends carries point load 'W'. At a distance $\frac{L}{3}$ from one end, maximum deflection in beam is

(1) $\frac{0.0164 WL^2}{EI}$	(2) $\frac{0.01775 WL^4}{EI}$
(3) $\frac{0.0165 WL^3}{EI}$	(4) $\frac{0.0178 WL^4}{EI}$

15. There are two shafts of same material, one shaft is solid with diameter 'D' while the other is hollow with external diameter 'D' and internal diameter $\frac{D}{2}$. Length of both shafts is equal and are used to transmit same torque. What is the ratio of angle of twist for hollow shaft to solid shaft ?

(1) $\frac{16}{15}$	(2) $\frac{10}{12}$
(3) $\frac{14}{13}$	(4) $\frac{11}{12}$

16. Principal stresses at a point in elastic material are '1.5 f' (tensile), 'f' (tensile) and $\frac{1}{2}f$ (compressive). If elastic limit in simple tension is 200 N/mm², what is the value of 'f' at failure according to maximum shear stress theory ?

(1) 200 N/mm ²	(2) 150 N/mm ²
(3) 125 N/mm ²	(4) 100 N/mm ²

17. When cantilever is loaded at its free end, then variation of bending stress across the section is
- (1) Linear (2) Parabolic
(3) Hyperbolic (4) Elliptic
-
18. Which of the following techniques does *not* require quenching to obtain final case hardness ?
- (1) Flame hardening (2) Induction hardening
(3) Nitriding (4) Carburizing
-
19. As compared to the engineering stress - engineering strain curve, the true stress - strain curve for a given material
- (1) lies above and to the left
(2) lies below and to the right
(3) crosses the engineering stress - strain curve
(4) is identical
-
20. Regarding recrystallization, which of the following statements is *not* correct ?
- (1) Higher the amount of cold work, lower is the recrystallization temperature.
(2) Higher the recovery, higher is the recrystallization.
(3) Higher is the temperature of cold work, higher is the recrystallization temperature.
(4) Finer the initial grain size, higher is the recrystallization temperature.
-
21. The microstructure of eutectoid steel is _____ at room temperature.
- (1) ferrite and pearlite (2) pearlite
(3) ferrite and austenite (4) cementite
-
22. The molten metal is forced through an orifice into a stream of high velocity air in _____.
- (1) sintering (2) granulation
(3) atomization (4) electrolysis

कच्च्या कामासाठी जागा / SPACE FOR ROUGH WORK

23. Muntz metal is an alloy of _____ .
- (1) zinc and lead (2) copper and zinc
(3) tin and zinc (4) lead and white metal
-
24. Creep is specially taken care of while designing _____ .
- (1) turbine rotor and casing (2) drilling machines
(3) shapers (4) refrigerators
-
25. In white cast iron, carbon is present as _____ .
- (1) graphite flakes (2) graphite nodules
(3) combined cementite (4) carbon does not exist
-
26. If the thermal conductivity is observed in decreasing order, which of the following lists is correct ?
- (1) Copper, Aluminium, Silver, Iron
(2) Silver, Copper, Aluminium, Iron
(3) Aluminium, Iron, Silver, Copper
(4) Iron, Silver, Copper, Aluminium
-
27. Convective heat transfer coefficient depends
- (1) only on thermodynamic and transport property of carrier fluid
(2) only on nature of fluid flow
(3) only on geometry of surface and prevailing thermal conditions
(4) All of the above
-
28. Time required to cool a heated copper ball depends on which of the following properties of copper ball ?
- (1) Thermal conductivity only
(2) Thermal conductivity and specific heat
(3) Specific heat only
(4) Thermal conductivity or specific heat

29. Real surface in radiation heat transfer is

- (1) black body
 - (2) gray body
 - (3) having emissivity dependence on the wavelength of radiation
 - (4) None of the above
-

30. If a heated plate is kept vertical in atmospheric air, its thermal boundary layer formation will be from

- (1) top end
 - (2) bottom end
 - (3) mid point of plate
 - (4) simultaneously from both ends
-

31. Plate heat exchanger does *not* have the following feature :

- (1) Very high film conductance on both sides of plate
 - (2) Requires much lower floor area as compared to shell and tube heat exchanger
 - (3) Less costly than shell and tube type for costly construction material
 - (4) Difficult to clean
-

32. Which statement is *not* true about Fick's law of mass transfer ?

- (1) Mass diffusion is due to concentration gradient.
 - (2) The movement of a diffusion substance is in the direction of increasing concentration.
 - (3) Diffusion constant for ideal gases is assumed constant.
 - (4) Law is valid for all states of matter.
-

33. Ratio of thermal diffusivity to mass diffusivity is designated by a non-dimensionless number, known as

- (1) Schmidt number
 - (2) Sherwood number
 - (3) Lewis number
 - (4) Stanton number
-

कच्च्या कामासाठी जागा / SPACE FOR ROUGH WORK

34. In the design of machine-parts, specific stiffness is an important parameter. This is given by which of the following expressions ?

(1) $\frac{\text{Strength}}{\text{Density}}$

(2) $\frac{\text{Young's modulus}}{\text{Density}}$

(3) $\frac{\text{Density}}{\text{Young's modulus}}$

(4) $\frac{\text{Density}}{\text{Strength}}$

35. The ability of a material to absorb energy per unit volume without fracture is known as

(1) Toughness

(2) Resilience

(3) Stiffness

(4) Yield strength

36. For ductile materials, design of shaft is based on which of the following failure theories ?

(1) Maximum normal stress theory

(2) Maximum shear stress theory

(3) Distortion energy theory

(4) Von Mises theory

37. The combined spring rate for springs connected in parallel having individual spring rates k_1, k_2, k_3 is given by

(1) $k = k_1 + k_2 + k_3$

(2) $\frac{1}{k} = \frac{k_1}{k_1 + k_2 + k_3}$

(3) $k = \frac{1}{\frac{1}{k_1} + \frac{1}{k_2} + \frac{1}{k_3}}$

(4) $\frac{1}{k} = \frac{1}{k_1} + \frac{1}{k_2} + \frac{1}{k_3}$

38. In the design of a solid circular shaft of diameter "d" and moment " M_t " based on torsional load condition, the torsional stress (τ_{xy}) is given by

$$(1) \quad \tau_{xy} = \frac{16 M_t}{\pi d^3}$$

$$(2) \quad \tau_{xy} = \frac{32 M_t}{\pi d^3}$$

$$(3) \quad \tau_{xy} = \frac{32 M_t}{\pi d^4}$$

$$(4) \quad \tau_{xy} = \frac{24 M_t}{\pi d^4}$$

39. A system of rotating masses is in dynamic balance, when there does **not** exist any _____.

- (1) resultant centrifugal force
- (2) resultant couple
- (3) resultant centrifugal force as well as resultant couple
- (4) unbalanced mass

40. How many degrees of freedom will a double pendulum as shown in the figure have ?

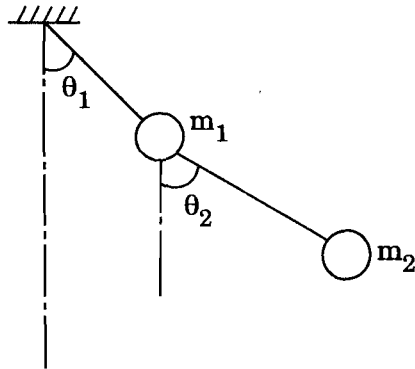

- (1) 1
- (2) 3
- (3) 2
- (4) Infinite

कच्च्या कामासाठी जागा / SPACE FOR ROUGH WORK

41. The equation of vibration of the water column in a U-tube as shown in figure is given by

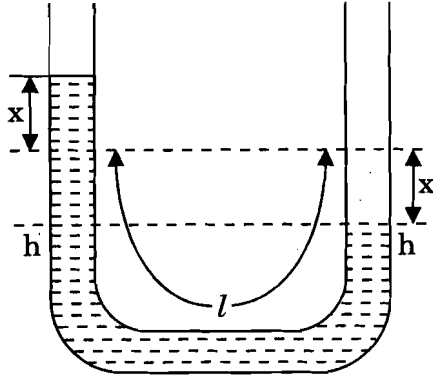

- (1) $\ddot{x} - \frac{2g}{l}x = 0$ (2) $\rho\ddot{x} + \frac{2g}{l}x = 0$
- (3) $\ddot{x} + \frac{2g}{l}x = 0$ (4) $\rho\ddot{x} - \frac{2g}{l}x = 0$

42. In case of large guns, to achieve minimum return time, the damping coefficient is kept

- (1) greater than one (2) equal to one
- (3) less than one (4) equal to two

43. When the shaft is bent alternately, and tensile and compressive stresses due to bending are developed, the vibrations in shaft are said to be

- (1) longitudinal (2) torsional
- (3) whirling (4) transverse

44. Which of the following specialised industrial devices is used for interfacing to and controlling analog and digital devices ?

- (1) PID controller (2) Adaptive control system
- (3) Programmable logic controller (4) PD controller

45. "Microprocessors" which have memory and various input/out arrangements on the same chip are called _____ .
- (1) buses (2) registers
(3) micro controllers (4) attenuators
-
46. Which of the following registers are used in microprocessor for temporary storage of operands or intermediate data in calculations ?
- (1) Instruction registers (2) General purpose registers
(3) Stack pointers (4) None of the above
-
47. Because of high power-to-weight ratio, the hydraulic systems find a wide range of use in
- (1) Machine tools (2) Speed governing systems
(3) Position control systems (4) All of the above
-
48. For majority of the plant and process control actions in petroleum, petrochemical, textile and food industries, which of the following systems is preferably employed ?
- (1) Hydraulic (2) Pneumatic
(3) Electrical (4) None of the above
-
49. Which of the following methods permits accurate computations of time-domain response in addition to yielding readily available frequency response information ?
- (1) Nyquist method (2) Nichols chart
(3) Root locus method (4) None of the above
-
50. The transient response of a system is mainly due to
- (1) inertia forces (2) internal forces
(3) stored energy (4) friction
-

कच्च्या कामासाठी जागा / SPACE FOR ROUGH WORK

51. Programmable logic controllers (PLC's) consist of CPU, memory and _____ circuitry as main components.

- (1) optical sensors (2) input/output
 (3) position control system (4) None of the above

52. The correct velocity triangle for the given slider-crank mechanism is shown by which of the following options ?

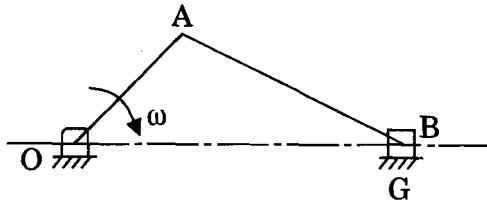
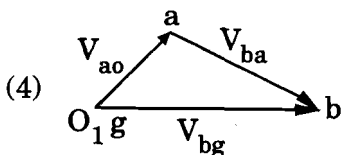
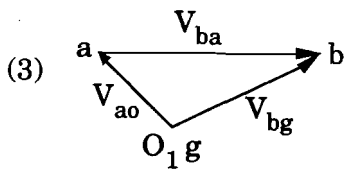
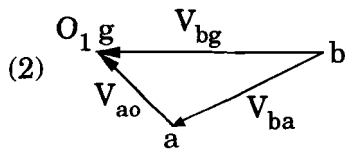
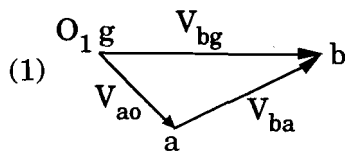

Fig. for Q 52



53. The number of instantaneous centers of rotation (ICR) for a mechanism with 'n' links is given by

(1) $N = \frac{n(n-1)}{4}$

(2) $N = \frac{2n(n-1)}{3}$

(3) $N = \frac{n(n-1)}{2}$

(4) $N = \frac{n(n+1)}{2}$

54. For the slider crank mechanism shown in figure, the centripetal component of acceleration of connecting link AB (B with respect to A) is acting

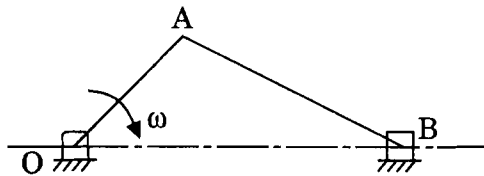

(1) along AB, directed from B to A

(2) along AB, directed from A to B

(3) perpendicular to AB at A

(4) perpendicular to AB at B

55. For a cam-follower mechanism, having disc cam with roller follower, the follower has constant acceleration and retardation motion. The velocity diagram for this motion is represented as,

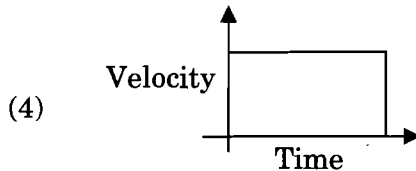
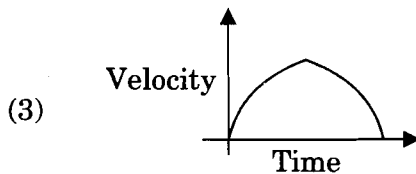
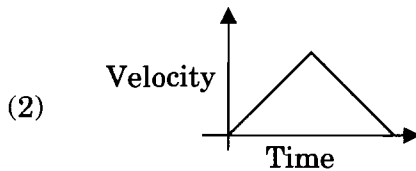
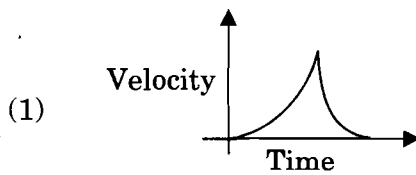

कच्च्या कामासाठी जागा / SPACE FOR ROUGH WORK

56. Two spur gears have a velocity ratio of $\frac{1}{3}$. The driven gear has 72 teeth of 8 mm module and rotates at 300 rpm. Then, the speed of driver gear is
- (1) 100 rpm (2) 300 rpm
(3) 900 rpm (4) 600 rpm

57. For the differential band brake shown in figure, the direction of externally applied force F is upwards for which of the following conditions ?

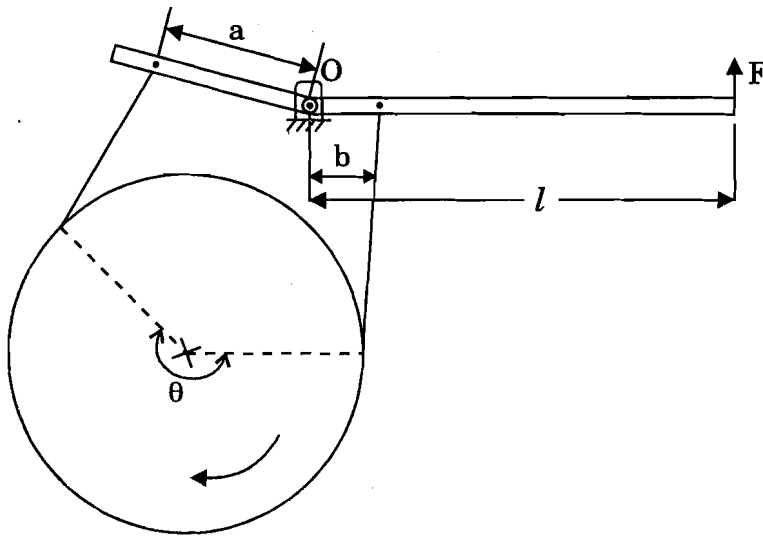

- (1) $a = b = 100$ mm
(2) $a = 125$ mm, $b = 100$ mm
(3) $a = 75$ mm, $b = 100$ mm
(4) $a = 200$ mm, $b = 100$ mm
-
58. The variation in the speed of the wheels along a curvature, for a four wheeled passenger car, is accomplished by which of the following ?
- (1) Sliding mesh gear box (2) Synchromesh gear box
(3) Differential gear box (4) Preselective gear box

59. Which type of gear train is shown in figure ?

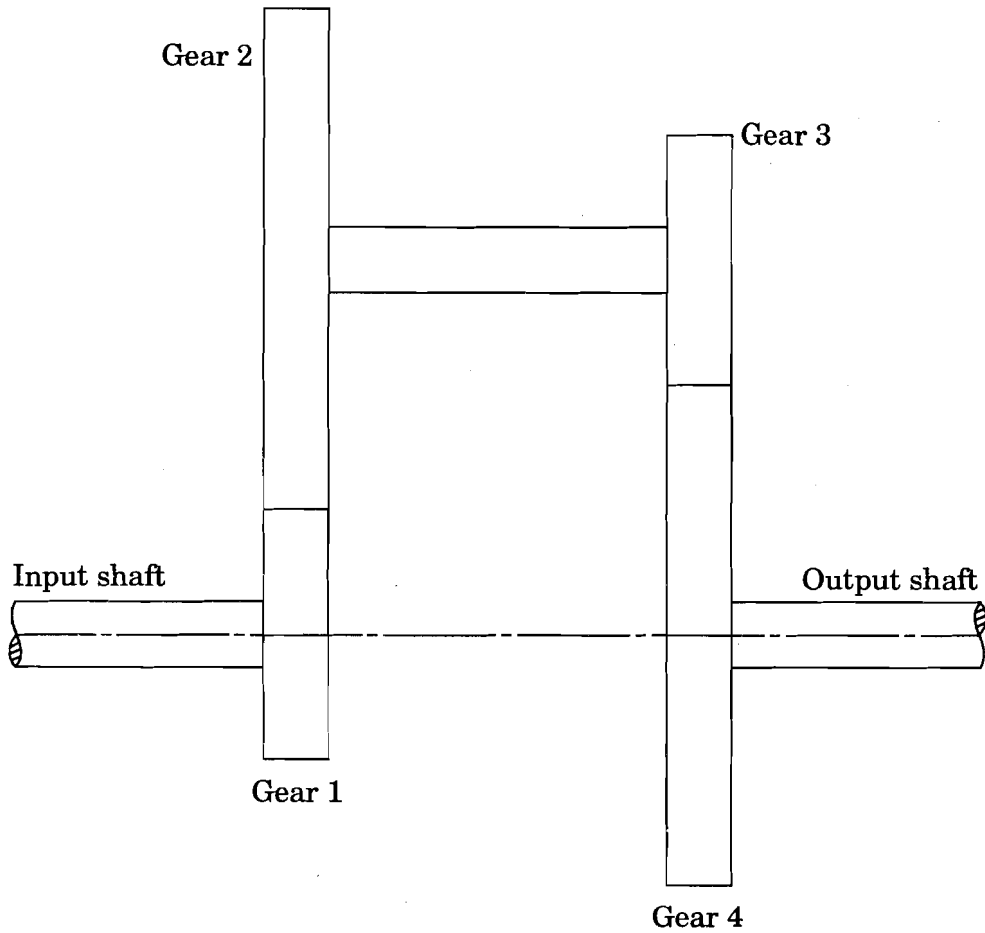

- (1) Simple gear train (2) Epicyclic gear train
 (3) Reverted gear train (4) Differential gear train

60. For a pair of gears in contact, contact ratio is

- (1) $\frac{\text{Arc of contact}}{\text{Circular pitch}}$ (2) $\frac{\text{Arc of contact}}{\text{Module}}$
 (3) $\frac{\text{Path of contact}}{\text{Module}}$ (4) $\frac{\text{Path of contact}}{\text{Circular pitch}}$

61. Which of the following governors is mostly used to drive a gramophone ?

- (1) Pickering governor (2) Watt governor
 (3) Porter governor (4) None of the above

कच्च्या कामासाठी जागा / SPACE FOR ROUGH WORK

62. A Hartnell governor is a _____ .
(1) pendulum type governor (2) spring loaded governor
(3) dead weight governor (4) inertia governor
-
63. The engine of an aeroplane rotates in a clockwise direction, when seen from the tail end and the aeroplane takes a turn to the left. The effect of the gyroscopic couple on the aeroplane will be
(1) to dip the nose and tail (2) to raise the nose and tail
(3) to dip the nose and raise the tail (4) to raise the nose and dip the tail
-
64. A disc is spinning with an angular velocity ω rad/sec about the axis of spin. The couple applied to the disc causing precession will be _____ .
Where I = Mass moment of inertia of disc
 ω_p = Angular velocity of precession of axis of spin.
(1) $\frac{1}{2} I\omega^2$ (2) $I\omega^2$
(3) $\frac{1}{2} I\omega\omega_p$ (4) $I\omega\omega_p$
-
65. If the speed of the engine controlled by the governor fluctuates continuously above and below the mean speed, the governor is said to be _____ .
(1) stable (2) unstable
(3) isochronous (4) hunting
-
66. Hammer blow is the maximum amplitude of the unbalanced force at an angle _____ with the line of stroke.
(1) 0° (2) 45° (3) 90° (4) 180°
-
67. Transmissibility is equal to one, at $\frac{\omega}{\omega_n} =$ _____ .
(1) 1.414 (2) 1 (3) 1.313 (4) 1.57

68. The relation between free and damped natural frequencies is given as _____, where ζ (zeta) is the damping ratio.

(1) $\omega_d = \sqrt{1 + \zeta^2} \omega_n$

(2) $\omega_d = \sqrt{1 - \zeta^2} \omega_n$

(3) $\omega_n = \sqrt{1 - \zeta^2} \omega_d$

(4) $\omega_n = \sqrt{1 + \zeta^2} \omega_d$

69. The swaying couple is maximum or minimum when the angle of inclination of the crank with the line of stroke is equal to _____.

(1) 25° and 115°

(2) 60° and 150°

(3) 120° and 310°

(4) 45° and 225°

70. Direct and Reverse crank method makes the analysis of forces simple in case of _____.

(1) V-engine

(2) In-line engine

(3) Radial engine

(4) None of the above

71. The tractive force is maximum or minimum when the angle of inclination of the crank with the line of stroke is equal to _____.

(1) 90° and 135°

(2) 135° and 315°

(3) 45° and 135°

(4) 135° and 180°

72. What is the logarithmic decrement if $\frac{\omega_n}{\omega_d} = 1.021$ and $\zeta = 0.2$? ($\zeta = \text{zeta}$)

(1) 1.31

(2) 1.28

(3) 1.41

(4) 1.37

73. The most common method of obtaining rich mixture during cold starting is

(1) Acceleration pump system

(2) Main metering system

(3) Idling system

(4) Application of choke

74. Which one of the following lubricating systems is used for two stroke IC engines ?

(1) Wet sump lubricating system

(2) Dry sump lubricating system

(3) Mist lubricating system

(4) Splash lubricating system

कच्च्या कामासाठी जागा / SPACE FOR ROUGH WORK

75. The second stage of combustion in C.I. engines after the delay period, is the period of
(1) physical delay (2) uncontrolled combustion
(3) controlled combustion (4) after burning
-
76. The _____ cooling system cannot be used in high output engines due to its inability to meet the requirement of large flow rates of water.
(1) evaporative
(2) thermo-syphon
(3) cooling with thermostatic regulator
(4) pump cooling
-
77. The ignition of the homogeneous mixture in the cylinder, before the timed ignition spark occurs, is known as
(1) Delay period (2) Pre-ignition
(3) Post ignition (4) None of the above
-
78. The ignition lag time in SI Engine is normally about
(1) 0.01 seconds (2) 0.0015 seconds
(3) 0.1 seconds (4) 1.1 seconds
-
79. Dissociation refers to disintegration of burnt gases at high temperatures and it is a/an
(1) reversible process (2) irreversible process
(3) quasi-static process (4) None of the above
-
80. The air standard efficiency of Otto cycle is given by
(1) $\eta = 1 + \frac{1}{(r)^{\gamma+1}}$ (2) $\eta = 1 - \frac{1}{(r)^{\gamma-1}}$
(3) $\eta = 1 - \frac{1}{(r)^{\gamma+1}}$ (4) $\eta = 1 + \frac{1}{(r)^{\gamma-1}}$
-
81. Which one of the following is true for fuel air cycles ?
(a) There is no chemical change in either fuel or air prior to combustion.
(b) Subsequent to combustion, the charge is always in chemical equilibrium.
(1) Only (a) (2) Only (b)
(3) Both (a) and (b) (4) None of the above

82. Which one of the following describes turbochargers of the engines ?
- (a) Centrifugal compressors driven by the exhaust gas turbines.
(b) Turbochargers will not draw upon the engine power.
- (1) Only (a) (2) Only (b)
(3) Both (a) and (b) (4) None of the above
-
83. Which of the following casting processes is widely used for making ornamental objects ?
- (1) Centrifugal casting (2) Slush casting
(3) Investment casting (4) Gravity die casting
-
84. If the hot working is completed much above the recrystallization temperature, then
- (1) the grain size starts decreasing and final grain size will be smaller than at starting.
(2) the resulting grain size will be fine.
(3) the grain size starts increasing and finally may end up as coarse grain size.
(4) the grain size is reduced and a large number of nucleation sites are developed for new crystals to form.
-
85. In Resistance welding, the factor R (Resistance of joint) is composed of
- (i) Resistance of electrodes
(ii) Contact resistance between the electrode and the work-piece
(iii) Contact resistance between the two work-piece plates
(iv) Resistance of work-piece plates
- (1) Only (i) and (ii) (2) Only (ii) and (iii)
(3) Only (i) and (iv) (4) All (i), (ii), (iii) and (iv)
-
86. The powder metallurgy technique is applicable for
- (1) Job type production (2) Batch type production
(3) Mass type production (4) None of the above

कच्च्या कामासाठी जागा / SPACE FOR ROUGH WORK

87. Polymers usually consist of carbon plus one or more other elements, such as

- (i) Hydrogen
 - (ii) Nitrogen
 - (iii) Oxygen
 - (iv) Chlorine
- (1) Only (i) and (iii) (2) Only (ii) and (iii)
(3) Only (i) and (iv) (4) All (i), (ii), (iii) and (iv)
-

88. In a CNC program block
N002 G02 G91 X40 Z40 ...,
G02 and G91 refer to

- (1) circular interpolation in counter-clockwise direction and incremental dimension
 - (2) circular interpolation in counter-clockwise direction and absolute dimension
 - (3) circular interpolation in clockwise direction and incremental dimension
 - (4) circular interpolation in clockwise direction and absolute dimension
-

89. In orthogonal cutting, shear angle is the angle between

- (1) shear plane and the direction of tool travel
 - (2) shear plane and the rake plane
 - (3) shear plane and the vertical direction
 - (4) shear plane and the direction of elongation of crystals in the chip
-

90. Chipping of the tool may occur

- (i) due to tool material being too brittle
 - (ii) as a result of crack in the tool
 - (iii) due to excessive static loading of the tool
 - (iv) due to weak design of the tool
- (1) Only (i) and (ii) (2) All (i), (ii), (iii) and (iv)
(3) Only (ii) and (iii) (4) Only (i) and (iii)
-

91. Two components of velocity in an incompressible fluid flow are given by $u = x^3 - y^3$ and $v = z^3 - y^3$. If origin is a stagnation point and $F(x, y) = 0$, the third velocity component will be _____.

(1) $w = 3(x^2 - y^2)z$

(2) $w = 3(y^2 - x^2)z$

(3) $w = (3y^2 - x^2)z$

(4) $w = (3x^2 - y^2)z$

92. Subsonic diffuser section is _____.

(1) divergent

(2) divergent-convergent

(3) convergent

(4) convergent-divergent

93. At sonic speed, Mach angle is _____.

(1) 0°

(2) 90°

(3) 30°

(4) 60°

94. The assumption *not* made in the derivation of Bernoulli equation is _____.

(1) inviscid flow

(2) steady flow

(3) two-dimensional flow

(4) uniform flow

95. In laminar flow, the value of momentum thickness is generally taken as _____.

(1) $\frac{1}{7}$ th of displacement thickness

(2) $\frac{1}{3}$ rd of boundary layer thickness

(3) $\frac{1}{7}$ th of boundary layer thickness

(4) $\frac{1}{3}$ rd of displacement thickness

96. The number of buckets for Pelton wheel with 30 cm runner diameter and 5 cm jet diameter is _____.

(1) 20

(2) 16

(3) 18

(4) 24

कच्च्या कामासाठी जागा / SPACE FOR ROUGH WORK

97. Minimum speed for starting delivery in a centrifugal pump depends on _____.

- | | |
|---------------------------|---------------------------|
| (1) overall efficiency | (2) mechanical efficiency |
| (3) volumetric efficiency | (4) manometric efficiency |

98. The volumetric efficiency of a reciprocating air compressor depends on _____.

- (1) pressure ratio only
- (2) clearance ratio only
- (3) both pressure ratio and clearance ratio
- (4) clearance volume

99. Slip in the case of a centrifugal pump _____.

- | | |
|---------------------------|---------------------------------|
| (1) reduces the flow rate | (2) reduces the energy transfer |
| (3) reduces the speed | (4) increases cavitation |

100. In a measurement system, which of the following static characteristics are desirable ?

- | | |
|---------------------|----------------------|
| (1) Accuracy | (2) Sensitivity |
| (3) Reproducibility | (4) All of the above |

101. Linear Variable Differential Transformer (LVDT) can be used to measure displacement ranging from

- | | |
|-----------------------|----------------------|
| (1) 1.25 mm to 250 mm | (2) 260 mm to 270 mm |
| (3) 280 mm to 290 mm | (4) All of the above |

102. Dummy strain gauges are used for

- (1) compensation of temperature changes
- (2) calibration of strain gauge
- (3) increasing the sensitivity of bridge circuit in which they are included
- (4) None of the above

103. The hand speed indicators can be used up to the speed of 20,000 rpm to 30,000 rpm with an accuracy of

- | | |
|------------------|------------------|
| (1) 0.15 percent | (2) 0.25 percent |
| (3) 0.35 percent | (4) 1.0 percent |

104. Variable reluctance transducers are ideally suitable for low pressure measurement as their sensitivity is

- (1) high (2) low
(3) zero (4) None of the above
-

105. Vacuum Pressure is

- (1) equal to gauge pressure
(2) equal to atmospheric pressure
(3) lower than atmospheric pressure
(4) equal to absolute pressure
-

106. Mercury is used in liquid filled system as it gives

- (1) high sensitivity
(2) wide temperature range
(3) wide temperature range and almost linear scale
(4) All of the above
-

107. Potentiometric Accelerometer is useful only for

- (1) low frequency application
(2) high frequency application
(3) both high and low frequency application
(4) None of the above
-

108. Which part classification and coding system uses the following digit sequence ?

12345 6789 ABCD

- (1) Code System (2) M1 Class System
(3) Opitz System (4) All of the above
-

109. In CNC Programming, M30 stands for

- (1) end of program (2) end of block
(3) end of tape and rewind (4) coolant on/off
-

कच्च्या कामासाठी जागा / SPACE FOR ROUGH WORK

110. C'' Continuity used in curves refers to

- | | |
|----------------------|---------------------|
| (1) common curvature | (2) common normal |
| (3) common points | (4) common tangents |
-

111. The screen is scanned left to right and top to bottom all the time to generate graphics by

- | | |
|-----------------|--------------------|
| (1) Vector scan | (2) Random scan |
| (3) Raster scan | (4) Stroke writing |
-

112. Which of the following algorithms are polygon clipping algorithms ?

- | | |
|-------------------------|-------------|
| A. Liang – Barsky | |
| B. Sutherland – Hodgman | |
| C. Cohen – Sutherland | |
| D. Weiler – Atherton | |
| (1) B and D | (2) A and B |
| (3) B and C | (4) A and C |
-

113. Which one of the following is *not* a graphic standard ?

- | | |
|---------|----------|
| (1) GKS | (2) STEP |
| (3) DXF | (4) UNIX |
-

114. To reflect any object about arbitrary line, composite transformation uses the following combination of transformations :

- (1) Translation + Shear + Rotation
 - (2) Translation + Rotation + Scaling
 - (3) Translation + Reflection + Scaling
 - (4) Translation + Rotation + Reflection
-

115. In APT, to specify feeds and speeds and to actuate other features of machine, statement type used is

- | | |
|----------------------------|-------------------------|
| (1) Geometry statement | (2) Auxiliary statement |
| (3) Post Process statement | (4) Motion statement |
-

116. Which thermodynamics law governs refrigerator ?
- (1) First Law of Thermodynamics
 - (2) Zeroth Law of Thermodynamics
 - (3) Second Law of Thermodynamics
 - (4) None of the above
-
117. If coefficient of performance of refrigerating machine is 4, what will be the temperature ratio $T_{\text{higher}} / T_{\text{lower}}$?
- (1) 0.8
 - (2) 1.25
 - (3) 4
 - (4) 2
-
118. Aircraft air refrigeration is used for _____ .
- (1) cooling cabin air
 - (2) maintaining cabin air pressure to 1 bar
 - (3) maintaining cabin temperature
 - (4) All of the above
-
119. Simple air refrigeration system is useful for
- (1) ground surface cooling and for low flight speed
 - (2) high flight speed in sonic range
 - (3) all conditions of aircraft
 - (4) None of the above
-
120. Standard vapour compression refrigeration system uses throttling device instead of expansion turbine due to
- (1) higher thermodynamic advantage
 - (2) low cost of compression
 - (3) None of the above
 - (4) thermodynamic disadvantage is circumvented by cost reduction advantage
-
121. What are the components of vapour absorption refrigeration cycle ?
- (1) Compressor, condenser, throttle valve and evaporator
 - (2) Compressor, condenser, expander and evaporator
 - (3) Absorber, generator, condenser, throttle valve and evaporator
 - (4) Absorber, pump, generator, valve, condenser, throttle valve and evaporator

कच्च्या कामासाठी जागा / SPACE FOR ROUGH WORK

122. The function of rectifier in vapour absorption refrigeration system of ammonia-water system is
- (1) remove traces of water from ammonia before it reaches to condenser
 - (2) cost reduction of plant
 - (3) absorbing more refrigerant
 - (4) reducing corrosion
-
123. Which of the following statements is *not* true, in case of Water-LiBr system used in water chiller ?
- (1) It is more suitable involving low temperature heat source such as solar energy, waste heat.
 - (2) Both generator and absorber run under high vacuum.
 - (3) Absorption chillers are available in capacities from 100 TR to 7500 TR.
 - (4) COP is more than unity.
-
124. What is the psychrometric process most commonly used for air-conditioning in hot and dry weather conditions ?
- (1) Heating and humidification
 - (2) Dehumidification and cooling
 - (3) Adiabatic saturation process
 - (4) None of the above
-
125. Maximum fenestration (solar heat gain) heat load at 3 – 6 P.M. occurs from glass work in the wall/window facing _____. (During Indian hot season May – June)
- (1) East
 - (2) West
 - (3) North
 - (4) South
-
126. Long-term forecasts are made for the purpose of
- (1) product diversification
 - (2) sales and advertising budgets
 - (3) capacity planning
 - (4) All of the above
-
127. The Hungarian Method for solving assignment problem requires
- (1) Square matrix
 - (2) 3×2 matrix
 - (3) Both of the above
 - (4) None of the above

128. If critical ratio is less than one, then
- | | |
|-----------------------------|----------------------------------|
| (1) job is critical | (2) job is ahead of the schedule |
| (3) job is just on schedule | (4) None of the above |
-
129. Programme Evaluation and Review Technique (PERT) takes into account
- | | |
|----------------------|----------------------|
| (1) Optimistic time | (2) Most likely time |
| (3) Pessimistic time | (4) All of the above |
-
130. Critical Path Method (CPM) is
- | | |
|-----------------------|-----------------------|
| (1) activity oriented | (2) one time estimate |
| (3) a planning device | (4) All of the above |
-
131. Basic elements of Just-in-Time (JIT) are
- | | |
|-----------------|--------------------------|
| (1) Flow layout | (2) Buffer stock removal |
| (3) Kanban card | (4) All of the above |
-
132. Output of material requirement planning can be
- | | |
|-------------------------------|------------------------|
| (1) order release requirement | (2) order rescheduling |
| (3) planned orders | (4) All of the above |
-
133. Principles of scheduling focus on
- | | |
|-----------------------|-----------------------------|
| (1) Optimum task size | (2) Optimum production plan |
| (3) Optimum sequence | (4) All of the above |
-
134. Casual Forecasting can be done by
- (1) Regression and correlation analysis
 - (2) Input – Output analysis
 - (3) End use analysis
 - (4) All of the above
-
135. Aggregate production planning determines
- | | |
|-----------------------------|-------------------------|
| (1) Regular time production | (2) Overtime production |
| (3) Subcontracting | (4) All of the above |
-

136. A thin planar body subjected to in-plane loading at its edge surface is said to be in _____.

- (1) Plane stress (2) Plane strain
(3) Both (1) and (2) (4) Neither (1) nor (2)
-

137. In _____ elements, the same interpolation function used to define the element geometry are also used to describe the variation of the field variable within the element.

- (1) parametric (2) isoparametric
(3) quadratic (4) cubic
-

138. If determinant of a square matrix A is equal to zero, then the matrix A is called _____, for which the inverse is _____.

- (1) non-singular, not defined (2) singular, defined
(3) singular, not defined (4) non-singular, defined
-

139. The term finite element was first coined and used by _____ in 1960.

- (1) Turner (2) Argyris
(3) Zienkiewicz (4) Clough
-

140. Maximum kinetic energy during motion is equated to the maximum potential energy in _____ method.

- (1) Galerkin's (2) Separation of variables'
(3) Laplace's (4) Rayleigh's
-

141. The three-dimensional simplex element is a flat-faced _____ with _____ nodes.

- (1) tetrahedron, three (2) tetrahedron, four
(3) cube, eight (4) square-pyramid, five
-

142. Evaluate the shape functions N_1 , N_2 and N_3 at the interior point P for the triangular element shown in the figure below.

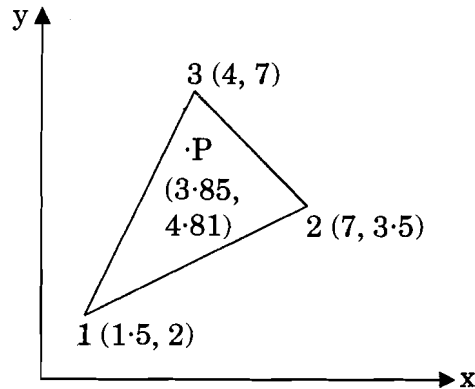

- (1) 0.3, 0.2, 0.5 (2) 0.2, 0.3, 0.5
 (3) 0.2, 0.4, 0.4 (4) 0.3, 0.4, 0.3

143. Ratio of maximum to minimum characteristic dimensions is called as _____.

- (1) characteristic ratio (2) aspect ratio
 (3) element ratio (4) parametric ratio

144. If the interpolation functions in the natural (local) coordinates satisfy continuity of _____ within the element and between adjacent elements, the compatibility requirement will be satisfied in the global coordinates.

- (1) geometry (2) field variable
 (3) geometry and field variable (4) geometry or field variable

145. The _____ of the overall or global characteristic matrix depends on the node numbering scheme and the number of degrees of freedom considered per node.

- (1) range (2) band width (3) rank (4) order

146. Estimate how many observations are needed (approx) if an assembly line has 10% of idle time. The expected accuracy in work sampling is $\pm 4\%$ for a 99.7% of confidence level. Assume $k = 3$ for 99.7% confidence level.

- (1) 506 (2) 510 (3) 502 (4) 512

कच्च्या कामासाठी जागा / SPACE FOR ROUGH WORK

147. Consider a time study of a product manufacturing by an operator of machine, whose rating is 95%. The data is as follows :

Observed time = 20 mins

Personal allowance = 4%,

Fatigue allowance = 2.5% of Basic time

Contingency delay allowance = 1% of Basic time

Contingency work Basic time = 2% of Basic time.

Determine work content time.

- | | |
|-------------------|-------------------|
| (1) 13.5 minutes | (2) 14.65 minutes |
| (3) 14.78 minutes | (4) 14.85 minutes |
-

148. Method Time Measurement time study uses unit of time in

- | | |
|------------------|------------------|
| (1) Nano seconds | (2) Pico seconds |
| (3) TMU | (4) Fermi |
-

149. The demand of spur gear produced by a company is uniform at 50 units/day. It is estimated that each time a production is set the company incurs ₹ 100 as fixed cost. Production cost is ₹ 10, carrying cost is ₹ 2 per unit per day and shortage cost is ₹ 6 per unit per day. Estimate optimal production quantity (approximate).

- | | |
|--------|--------|
| (1) 85 | (2) 87 |
| (3) 84 | (4) 82 |
-

150. Arrange sequence of Data flow in manufacturing modules of ERP (Enterprise Resource Planning) :

- (a) Material Requirements Planning (MRP)
 - (b) Aggregate planning
 - (c) Master Production Scheduling (MPS)
 - (d) Shop Floor Control (SFC)
- | |
|------------------------|
| (1) (a), (b), (c), (d) |
| (2) (d), (c), (a), (b) |
| (3) (b), (c), (a), (d) |
| (4) (b), (c), (d), (a) |
-

कच्चा कामासाठी जागा / SPACE FOR ROUGH WORK

सूचना - (पृष्ठ 1 वरून पुढे.....)

- (8) प्रश्नपुस्तिकेमध्ये विहित केलेल्या विशिष्ट जागीच कच्चे काम (रफ वर्क) करावे. प्रश्नपुस्तिकेव्यतिरिक्त उत्तरपत्रिकेवर वा इतर कागदावर कच्चे काम केल्यास ते कॉपी करण्याच्या उद्देशाने केले आहे, असे मानले जाईल व त्यानुसार उमेदवारावर शासनाने जारी केलेल्या “परीक्षांमध्ये होणाऱ्या गैरप्रकारांना प्रतिबंध करण्याबाबतचे अधिनियम-82” यातील तरतुदीनुसार कारवाई करण्यात येईल व दोषी व्यक्ती कमाल एक वर्षाच्या कारावासाच्या आणि/किंवा रुपये एक हजार रकमेच्या दंडाच्या शिक्षेस पात्र होईल.
- (9) सदर प्रश्नपत्रिकेसाठी आयोगाने विहित केलेली वेळ संपल्यानंतर उमेदवाराला ही प्रश्नपुस्तिका स्वतःबरोबर परीक्षाकक्षाबाहेर घेऊन जाण्यास परवानगी आहे. मात्र परीक्षा कक्षाबाहेर जाण्यापूर्वी उमेदवाराने आपल्या उत्तरपत्रिकेचा भाग-1 समवेक्षकाकडे न विसरता परत करणे आवश्यक आहे.

नमुना प्रश्न

प्र. क्र. 201. The Catch varies inversely with the size of the

- (1) nozzle (2) droplet
(3) obstruction (4) sprayer

ह्या प्रश्नाचे योग्य उत्तर “(3) obstruction” हे आहे. त्यामुळे या प्रश्नाचे उत्तर “(3)” होईल, आता खालीलप्रमाणे प्रश्न क्र. 201 समोरील उत्तर-क्रमांक “(3)” चा कंस खालीलप्रमाणे पूर्णपणे छायांकित करून दाखविणे आवश्यक आहे.

प्र. क्र. 201. (1) (2) ● (4)

अशा पद्धतीने प्रस्तुत प्रश्नपुस्तिकेतील प्रत्येक प्रश्नाचा तुमचा उत्तरक्रमांक हा तुम्हाला स्वतंत्ररीत्या पुरविलेल्या उत्तरपत्रिकेवरील त्या त्या प्रश्नक्रमांकासमोरील संबंधित वर्तुळ पूर्णपणे छायांकित करून दाखवावा. ह्याकरिता फक्त काळ्या शाईचे बॉलपेन वापरावे, पेन्सिल वा शाईचे पेन वापरू नये.

कच्च्या कामासाठी जागा / SPACE FOR ROUGH WORK

SEAL